

Sensors for strong acids 4338 & 4339

4338 with tantalum electrodes, 4339 with platinum electrodes

4-electrode conductivity sensor with internal electrodes.
Used with TCU series 3100 and 3300.

Technical data	
Materials	PTFE and steel W 1.4404 (AISI 316L) Wetted parts: PTFE and Tantalum (4338) PTFE and Platinum (4339)
Pressure	12 bar at 120 °C
Cell constant	Sensor specific, factory calibrated
Accuracy	± 1 %
Meas. range	20...5 000 000 μS/cm
Linearity	± 1 % per decade
Temp. sensor	Pt 1000 (IEC 751 class A) Time delay T_{90} , 110 sec
Protection	IP65 splash-proof (DIN 40 050)
Sensor cable	PVC 12 x 0.25 mm ² screened max. temp. 70 °C
Cable length	Standard length 5 m COND15240-10 -> 10 m COND15240-15 -> 15 m
Connection	11-pole strip connector with MF20 cable adapter
Weight	1.8 kg

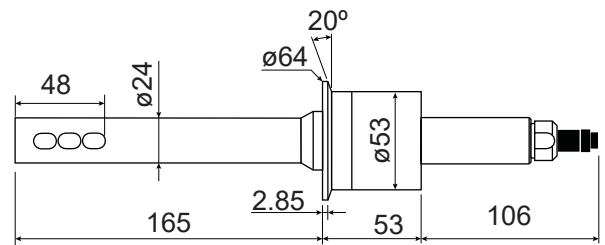

dimensions in millimeters

Typical uses

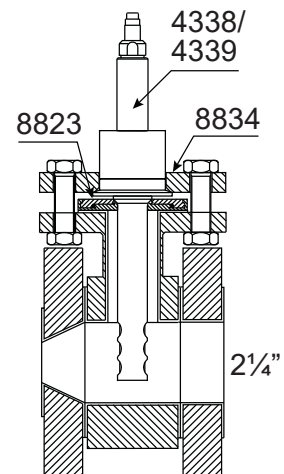
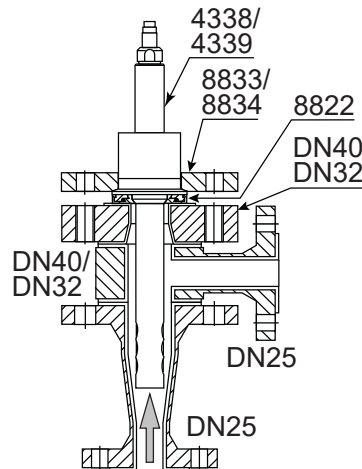
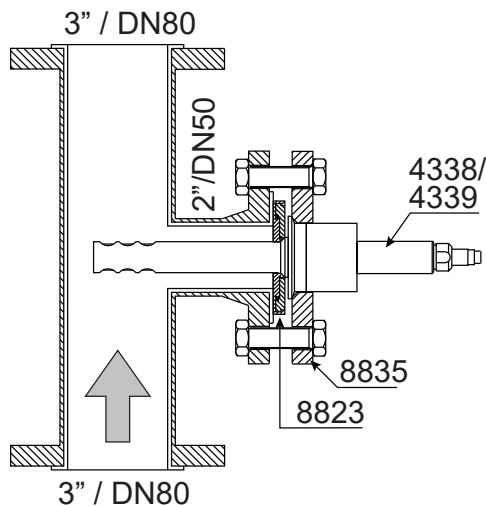

PTFE intermediate flanges

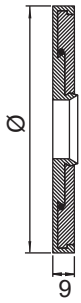

Type	Ø	DN	ANSI
8822	63.5	25	1¼"
		32	1½"
8823	88	40	2"
		50	



DIN slip-on flanges

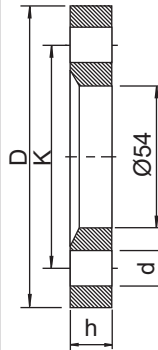

Type	DN	D	K	h	d	torque
8831	kt	90	75	14	10.5	12 Nm
8832	25	115	85	14	14	14 Nm
8833	32	140	100	16	18	16 Nm
8834	40	150	110	16	18	25 Nm
8835	50	165	125	16	18	21 Nm

ANSI slip-on flanges

Class	Type	ANSI	D	K	h	d	torque
300	8842	1¼"	133.3	98.4	17.4	19.0	20 Nm
	8843	1½"	155.6	114.3	20.6	22.2	20 Nm
	8844	2"	165.1	127.0	22.2	19.0	14 Nm
150	8846	1¼"	117.5	88.9	15.9	15.9	16 Nm
	8847	1½"	127.0	98.4	17.5	15.9	14 Nm
	8848	2"	152.4	120.6	19.0	19.0	27 Nm

Mountings with service valves

